

DATA SHEET

AIR KNIFES

for side channel blowers
for consolidated controls of air flow

MAKE IT BECKER.



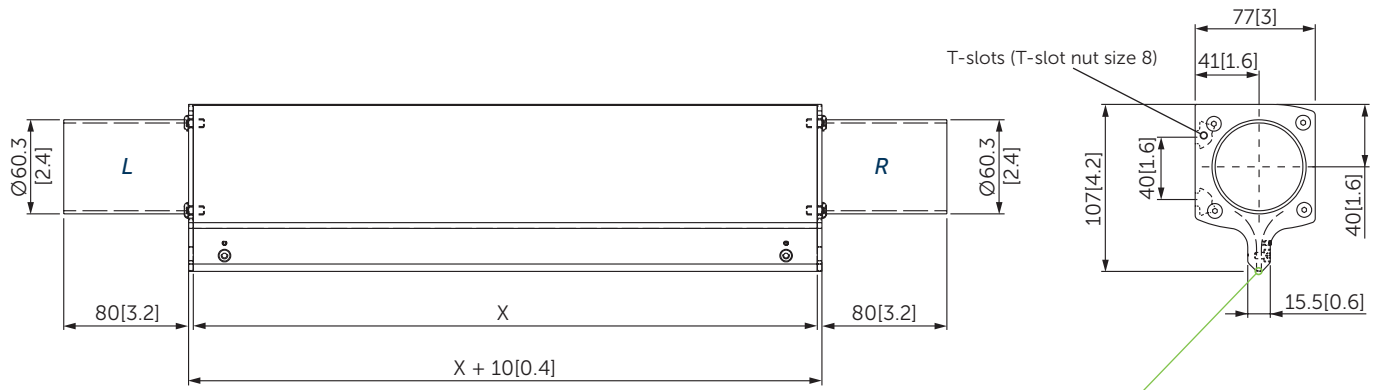

	Active length X	Connection on side	Material (connection)	Order no.
AIR KNIFE 200-0-1	200	L	AL (V2A)	75840400000
AIR KNIFE 200-0-2	200	R	AL (V2A)	75840500000
AIR KNIFE 230-0-2	230	R	AL (V2A)	75841800000
AIR KNIFE 300-0-1	300	L	AL (V2A)	75841500000
AIR KNIFE 400-0-1	400	L	AL (V2A)	75842000000
AIR KNIFE 500-0-1	500	L	AL (V2A)	75840200000
AIR KNIFE 600-0-1	600	L	AL (V2A)	75840300000
AIR KNIFE 600-0-2	600	R	AL (V2A)	75843100000
AIR KNIFE 678-0-1	678	L	AL (V2A)	75841000000
AIR KNIFE 700-0-1	700	L	AL (V2A)	75842100000
AIR KNIFE 800-0-1	800	L	AL (V2A)	75840700000
AIR KNIFE 850-0-1	850	L	AL (V2A)	75842700000
AIR KNIFE 850-0-2	850	R	AL (V2A)	75842900000
AIR KNIFE 900-0-1	900	L	AL (V2A)	75842200000
AIR KNIFE 900-0-2	900	R	AL (V2A)	75843200000
AIR KNIFE 978-0-1	978	L	AL (V2A)	75840900000
AIR KNIFE 1000-0-1	1000	L	AL (V2A)	75840100000
AIR KNIFE 1000-0-3	1000	L + R	AL (V2A)	75840800000
AIR KNIFE 1100-0-1	1100	L	AL (V2A)	75842800000
AIR KNIFE 1100-0-2	1100	R	AL (V2A)	75843000000
AIR KNIFE 1200-0-1	1200	L	AL (V2A)	75842300000
AIR KNIFE 1500-0-3	1500	L + R	AL (V2A)	75841700000
AIR KNIFE 1800-0-3	1800	L + R	AL (V2A)	75841900000
AIR KNIFE 2600-0-3	2600	L + R	AL (V2A)	75841600000

▪ Dimensions in mm [inch]

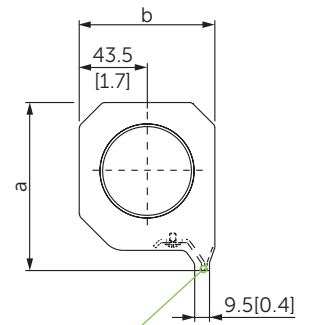
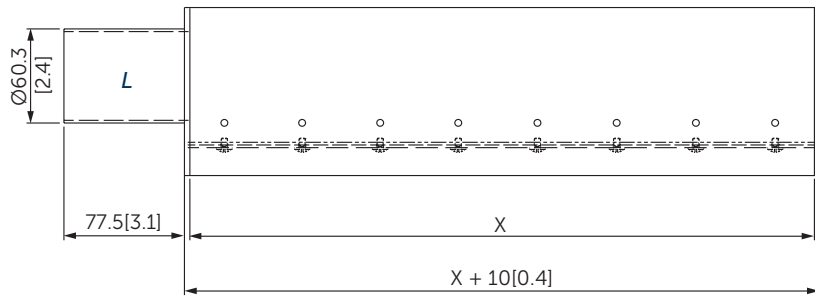

Before commissioning, the air nozzle must be set by the customer to match the application!
Adjustment range: 0.5-5.0 mm [0.02-0.2 inch]

	Active length X	Connection on side	Material (connection)	a	b	Order no.
AIR KNIFE 230-0-4	230	L	V2A (V2A)	90	70	75841100000
AIR KNIFE 230-0-7	230	L	V2A (V2A)	107	87	75841300000
AIR KNIFE 300-0-4	300	L	V2A (V2A)	90	70	75840600000
AIR KNIFE 500-0-4	500	L	V2A (V2A)	90	70	75841200000
AIR KNIFE 500-0-7	500	L	V2A (V2A)	107	87	75841400000

▪ Dimensions in mm [inch]



MAKE IT BECKER.